



# High Temperature Hot Water Boilers (Section I) Power Burner Fired

## PRODUCT DESCRIPTION

Rite has manufactured High Temperature Hot Water Boilers with safety and reliability in mind for well over forty years. From large central heating plants to a wide variety of industrial process loads, these heavy duty watertube boilers are available in 16 different models, ranging from 398 to 10,456 MBH input (9.5 - 250 Boiler Horsepower). Capable of providing 250° to 340°F water or higher, these boilers compare favorably to thermal hot oil heaters and high pressure steam boilers. High temperature water boilers have •no high cost thermal oil fluid • no coking • no environmental spill issues • superior heat transfer efficiency over thermal oil. Benefits over steam include • no auxiliary equipment such as : blowdown tanks, deaerators, water softeners, chemical treatment, feed pumps, steam traps, condensate return lines • no "open system" energy losses • less scale and corrosion.

So simple to maintain and operate, Rite High Temperature Hot Water Boilers feature complete waterside access so that virtually all scale and mud deposits can be seen and mechanically cleaned during a single scheduled maintenance shutdown. **The result - Better fuel-to-water efficiency and lower operating cost over the life of your boiler investment.** Consider a few of our other standard features: • Rite's floating heads that eliminate pressure vessel cracks and broken welds caused by thermal stress cycling (backed by our **25 Year Thermal Shock Warranty**) • Tubesheets up to 1-3/4" thick that virtually eliminates tube loosening or weeping- and you have a better boiler by design.

## RITE POWER BURNER FEATURES

Rite Power Burner Fired High Temperature Water Boilers must be specified when: Low NOx emissions are required or fuels other than natural gas will be used. While Power Burners are more expensive and use more electrical power than atmospheric, they do have one substantial advantage: by controlling the amount of air they use for combustion, Power Burners achieve higher combustion efficiencies than atmospheric – especially at less than full fire rate.





# High Temperature Hot Water Boilers (Section I)

## Power Burner Fired MODELS & RATINGS

### STACK / DRAFT REQUIREMENTS

- UL listed for use with Type B Vent when power burner is for natural or L.P. gas fired only.
- Type 304 stainless steel lined stack is required when equipped with #2 oil or combination gas & #2 oil burner.
- Minimum stack height for natural or L.P. gas fired burners is 10 feet. Minimum height for #2 oil or combination gas & #2 oil fired boilers is 15 ft.
- The stack should be supported independently of the boiler and an adjustable length section of stack should be installed after the barometric damper to allow for servicing. All Rite Boilers have internal stack supports to handle the weight of the stack during installation.
- Power Burner fired boilers are supplied with a barometric damper (shipped loose) and a draft gauge (installed) to help set and maintain a draft between -.05" to -.09" W.C. for all fuels and firing rates.

### COMBUSTION / VENTILATION AIR

- Provide at least 1/2 square feet of free air opening from outside for every 1000 MBTUH input for combustion air. Louvers can significantly reduce effective free air opening so be sure to compensate accordingly.
- Provide the same size free opening at a high point in the room for ventilation
- If additional ventilation is required it is better to force air into the room. Avoid exhaust fans whenever possible. Minimum height for #2 oil or combination gas & #2 oil fired boilers is 15 ft.
- Motorized fresh air dampers must be interlocked with boiler controls to prevent firing unless fully open.
- Check local codes for exceptions and additional requirements to the above.

### B.T.U. FORMULA

- BTU Output @ 0-2000' elevation = 60 x 8.3 x ΔT x G.P.M.

### ELECTRICAL REQUIREMENTS

- We need to know the exact voltage, phase and cycles (hertz) you **want to use ahead of time**. Choose from 120, 208-240, 440-460 and 575 VAC. If the blower motor voltage is greater than 120 VAC, then a control stepdown transformer must be specified or separate 120 VAC power supply **must** be brought to the burner. All power supply is AC (alternating current) and assumed to be 60 cycles. Note that 50 cycles will reduce burner capacity and require 50 cycle rated valves and controls.

### FUEL REQUIREMENTS

- The type of gas (natural, propane, digester) and the supply gas pressure are required ahead of time. Specific gravity and BTU content are required for elevations above 2000' and on all digester gas jobs. Digester gas must be scrubbed and dried. Propane gas lines should use vaporizers to prevent freezing. All gas supply lines require a dirt/drip leg at the boiler. Do not use teflon tape on pipe threads.
- #2 oil (Diesel) supply pressure to burner oil pump: minimum gravity flow to maximum 3 psi.

### ELEVATION DERATION

Ratings are for elevations up to 2000 feet above sea level. Over 2000' ratings should be reduced at the rate of 4% for every 1000 feet **above** 2000 feet.

### WATER TEMPERATURES & PRESSURE DROPS

To prevent high temperature hot water from flashing to steam, a certain amount of overpressure is required. Look up the maximum operating temperature you want in the steam tables and find the corresponding pressure (i.e., 331°F = 90 psi steam). Add 20 psi and an additional 1 psi for every 1000' Elevation to determine safe operating pressure. E.g., 331°F water at 5000' would require 115 psi operating pressure.

BOILER MODEL	Input MBH	Nominal Output		Heating Surface Sq. Ft.	Water Content Gallons	G.P.M. @ 20°F Rise	G.P.H. 100°F Rise	Nominal Shipping Weight (lbs)
		MBH	Boiler Horsepower					
PW9.5 *	398	318	9.5	65	35	30	10	2550
PW10 *	419	335	10	65	35	32	10	2550
PW15 *	628	502	15	85	40	48	14	2950
PW20 *	838	670	20	105	45	65	16	3250
PW25 *	1046	837	25	115	65	80	18	4350
PW35 *	1465	1172	35	156	85	115	27	5050
PW48 *	1950	1560	48	214	100	152	39	6050
PW50 *	2093	1674	50	214	100	165	39	6050
PW75 *	3139	2511	75	349	150	245	69	11500
PW100 *	4185	3348	100	460	175	330	92	13200
PW125 *	5230	4184	125	571	195	415	118	15300
PW150 *	6267	5021	150	733	280	495	137	24300
PW175 *	7323	5858	175	851	320	580	157	25200
PW200*	8369	6695	200	969	360	650	185	26700
PW225 *	9452	7540	225	1020	390	750	208	27100
PW250 *	10456	8365	250	1125	420	830	223	28000

\*Add suffix "G" for natural gas or propane, "O" for #2 oil, "GO" for combination gas & #2 oil or "GG" for dual gas fuels (i.e. Natural & Digester). Add prefix "W" in front of model number for weatherproof (outdoor trim).



# High Temperature Hot Water Boilers (Section I)

## Power Burner Fired MODELS & DIMENSIONS

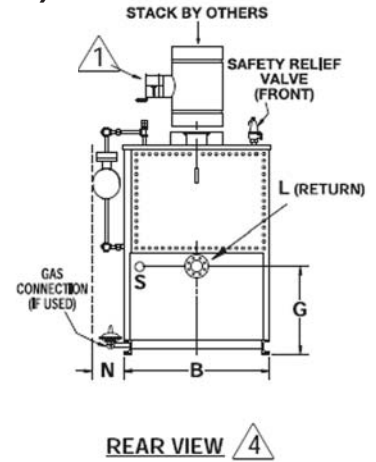
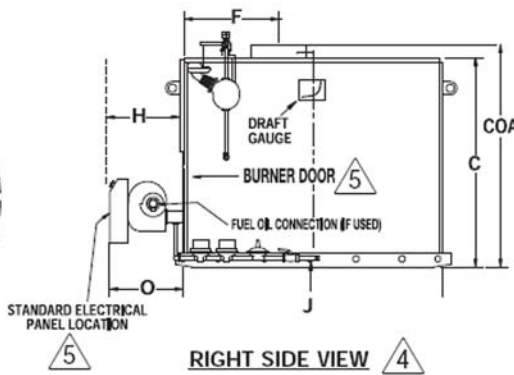
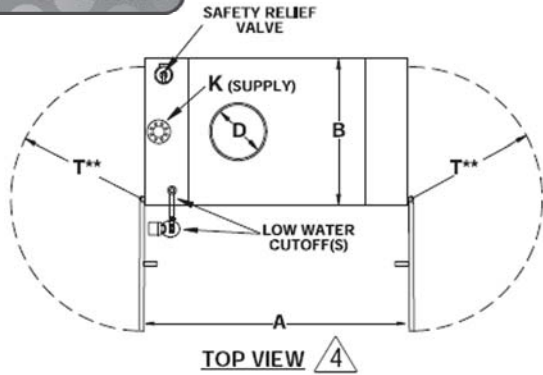

- DIMENSIONS ARE IN INCHES - SUBJECT TO PRODUCTION TOLERANCES AND CHANGE WITHOUT NOTICE. CERTIFIED DIMENSIONS AVAILABLE UPON REQUEST.
- OILERS APPROVED FOR INSTALLATION ON NON - COMBUSTIBLE FLOORS ONLY.

△1 A Barometric Damper will be provided & shipped loose one size smaller than **D** dimension for stacks up to 25 feet of vertical height as shown below in column **E**. A Full size damper (same as **D** dimension) should be specified for stacks 25 to 50 feet tall and one size larger for stacks over 50 feet tall. Barometric dampers 10" and larger come with mounting collar for single wall stack. Stack height should be given when placing order to assure proper size draft control is supplied.

△2 May vary - sizes shown are for UL gas trains at standard supply pressures. Gas connections can be male or female NPT.

△3 2" and smaller pipe connections are FNPT; all others flanged. Flanges are ANSI **300 lb.** SA-105 raised face.

△4 Standard right hand construction shown illustrated above. Left hand construction available at no extra charge.

△5 Models PW9.5 - PW50 have **hinged burner doors**. Do Not stub electrical conduit up in front of door or run rigid conduit directly to the panel as this will prevent access to the combustion chamber.

BOILER MODEL	Length Jacket	B	C	COA	D	E △	F	G	H	J △	K △	L	N	O	S	T
		Width Jacket	Height Flush	Height Overall	Stack Dia.		Stack Con	Rear C/L.	Tube Maint.	Gas Conn.	Water Supply	Water Return	Side Space	Power Burner	Drain	Head-Plate Swing
PW9.5 *	44	34	71	75	9	8 BARO	17	38	37	3/4	2	2	10	26	1	24
PW10 *	44	34	71	75	9	8 BARO	17	38	37	3/4	2	2	10	26	1	24
PW15 *	54	34	71	75	10	9 BARO	20	38	47	1	2	2	12	26	1	24
PW20 *	64	34	71	75	12	10 BARO	24	38	57	1	2	2	12	26	1	24
PW25 *	56	42	76	80	14	12 BARO	22	35	46	1 1/4	3 FL	3 FL	12	26	1 1/2	32
PW35 *	70	42	76	80	16	14 BARO	27	35	60	1 1/2	3 FL	3 FL	12	31	1 1/2	32
PW48 *	90	42	76	80	18	16 BARO	34	35	80	2	3 FL	3 FL	12	31	1 1/2	32
PW50 *	90	42	76	80	18	16 BARO	34	35	80	2	3 FL	3 FL	14	31	1 1/2	32
PW75 *	89	59	84	89	22	20 BARO	37	44	75	2	4 FL	4 FL	14	35	1 1/2	25
PW100 *	111	59	84	89	24	20 BARO	44	44	97	2	4 FL	4 FL	16	35	1 1/2	25
PW125 *	133	59	84	89	26	24 BARO	52	44	119	2	4 FL	4 FL	16	35	1 1/2	25
PW150 *	124	78	96	101	28	24 BARO	45	46	109	2 1/2	6 FL	6 FL	16	35	2	36
PW175 *	139	78	96	101	30	28 BARO	50	46	124	2 1/2	6 FL	6 FL	16	35	2	36
PW200 *	154	78	96	101	30	28 BARO	55	46	139	2 1/2	6 FL	6 FL	18	42	2	36
PW225 *	165	78	96	101	32	28 BARO	59	46	150	2 1/2	6 FL	6 FL	18	42	2	36
PW250 *	176	78	96	101	34	28 BARO	62	46	161	2 1/2	6 FL	6 FL	18	42	2	36

\* Add suffix "G" for natural gas or propane, "O" for #2 oil, "GO" for combination gas & #2 oil or "GG" for dual gas fuels (i.e. Natural & Digester). Add prefix "W" in front of model number for weatherproof (outdoor trim).

\*\*Option feature, must be specified. PW75-PW250 use a roller pivot design, see website video for details.



# High Temperature Hot Water Boilers (Section I)

## Power Burner Fired

### SPECIFICATION & ORDER FORM

#### **Boiler Capacity**

The Boiler shall be a Rite Model \_\_\_\_\_ Hot Water boiler with a capacity of \_\_\_\_\_ MBH input and a nominal output of \_\_\_\_\_ MBH (\_\_\_\_\_ Boiler Horsepower).

#### **Pressure Vessel**

The boiler shall be ASME Section I stamped for 150 PSIG or greater and registered with the National Board. It shall be of the inclined water tube design with 2" non-proprietary straight "see through" steel tubes (SA 178 Grade A, 13 Gauge) rolled between two headers (steel drums). Headers shall be free to expand and contract (no stay bolts shall be used) in order to reduce stresses caused by "thermal shock".

#### **Headers (Water Drums)**

Both headers shall incorporate bolted-and-gasketed removable head-plates that will completely expose all waterside surfaces for inspection and cleaning when opened. Header flanges shall have drilled and tapped smooth surfaces for easy gasket clean-up and flange maintenance. Flange welded studs shall not be used. Headplates shall be insulated.

#### **Water Trim**

Standard water trim shall include safety relief valve(s) set at 150 psi minimum and a probe or float type low water cutoff (manual reset) rated for a minimum of 150 psi service. A high limit (manual reset) and operating control shall prevent the boiler water temperature from exceeding 350°F or higher. Separate pressure and temperature gauges shall be provided near the hot water outlet. An air elimination fitting shall be provided. A water flow switch is not required and the boiler shall be capable of firing and brought up to temperature with the system pump off without damaging the tubes or pressure vessel.

#### **Warranty**

The boiler shall carry a twenty-five year thermal shock warranty and a twenty-five year tube erosion warranty in addition to a standard parts and workmanship warranty.

#### **Listings/Approvals**

In addition to the ASME & National Board Certifications, the boiler/burner package shall meet the requirements of CSD-1.

#### **Stack Requirements**

If gas fired (Natural or LP) the boiler shall be recognized as a Category 1 appliance and U.L. listed for use with Type B Gas Vent. If #2 oil fired, combination gas and #2 oil fired or digester gas fired, then the boiler shall be recognized as a Category 3 appliance and the stack inner liner shall be stainless steel. All models shall be supplied with a barometric damper (shipped loose) and a draft gauge installed near the controls with the proper draft range shown in inches water column.

#### **Burner**

The burner shall be power type with a blower motor and have air-fuel adjustment throughout the firing range. It shall have a burner mounted panel to house all burner controls including a stepdown control transformer for all three phase burner motors and a manual potentiometer for modulating burners.

#### **Flame Safeguard**

The flame safeguard control shall incorporate E-PROM memory and be capable of incorporating a message center. Main Flame shall be supervised when inputs are over 2500 MBH. U.V. scanner and spark ignition are standard unless otherwise specified.

#### **Gas Train – if used**

The gas train shall be completely piped and wired with a minimum of two main safety gas shutoff valves wired in series. It shall also include a main and pilot gas pressure regulator, each suitable to handle the specified maximum supply gas pressure. Valve leak test cocks shall be provided. High and low gas pressure switches shall be provided for inputs over 2500 MBH. A motorized main safety shutoff valve with proof of closure shall be provided for inputs over 5000 MBH.

#### **Oil Piping – if used**

The oil valve train shall consist of a minimum of two oil safety shutoff valves in series.

#### **Electrical**

The boiler/burner circuit shall require only one supply voltage and point of connection unless otherwise specified.

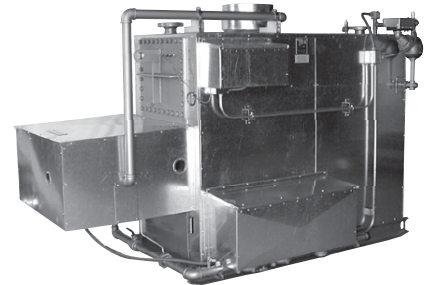

#### **Options**

The following options shall also be required:

- \_\_\_\_\_ Hinged Headplates (front & rear)
- \_\_\_\_\_ Insulated Headplates (front & rear)
- \_\_\_\_\_ 3 X 4 Handholes (front & rear)
- \_\_\_\_\_ Factory Mutual approvals
- \_\_\_\_\_ Industrial Risk Insured approvals
- \_\_\_\_\_ Other (See corresponding Green Price List C for more options)

---



---



---



---



---